

Linear Magnetic Measurement System LI50/B2

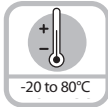

High IP



Temperature



Shock/vibration resistant



Reverse polarity protection

Robust

- **fully potted diecast metal housing.**
- **Increased ability to withstand vibrations and rough installation:** Eliminates machine downtime and repairs. Non-contact technology results in high shock and vibration resistance.
- **Stays sealed even when subjected to harsh everyday use.** Die cast metal housing with up to IP67 protection.



Compact

- **Installation depth only 10 mm, width of magnetic band 10 mm.**
- **Installation height only 28 mm.** May be used even where space is very tight.

Simple installation

- **fast start-up of the measuring system:** Easy attachment of the magnetic band and the sensor head.
- **Easy mounting with large tolerances possible:** Distance of sensor head to magnetic band from 0.1 to 2.0 mm; tolerates lateral misalignment +1 mm; LED warning indicator when magnetic field is too weak.

Technical data magnetic sensor LI50:

Output circuit:	Push-Pull	RS422
Supply voltage:	4.8 to 30 VDC	4.8 to 26 VDC
Load/channel, max cable length:	±20 mA, max. 30 m	120 Ohm, RS422 standard
Current consumption (without load):	typ. 25 mA, max. 60 mA	
Short circuit proof outputs: ¹⁾	yes	yes ²⁾
Min. Pulse interval:	1 μs (edge interval) corresponds to 4 μs/cycle (see signal figures below)	
Output signal:	A, \bar{A} , B, \bar{B} , I, \bar{I}	
Reference signal:	Index periodical	
System Accuracy:	typ. 200 μm, max. ±(0.06 + 0.04 x L) mm, (L in [m], up to L = 50 m, at T = 20°C)	
Repeat accuracy:	±1 increment	
Resolution and speed: ³⁾	25μm (post-quadrature), max. 16.25 m/s 5 μm (post-quadrature), max. 3.25 m/s	
Permissible alignment tolerance:	see draft "Mounting tolerances"	
Gap sensor / magnetic band:	0.1-2.0 mm (1.0 mm recommended)	
Offset:	max. ±1 mm	
Tilting:	max. 3°	
Torsion:	max. 3°	
Working temperature:	-4 to +176°F (-20 to +80°C)	
Shock resistance:	500g/1 ms	
Vibration strength:	30 g/10-2000 Hz	
Protection class:	IP67 according to DIN 60 529 (housing)	
Humidity:	100%, condensation possible	
Housing:	Zinc die-cast	
Cable:	2 m, PUR 8 x 0.14 mm ² , shielded, may be used in trailing cable installations	
Status-LED:	Green: Pulse-index; Red: Error Speed too high or magnetic fields too weak (for sensors T8.LI50.XXXX.X050 and T8.LI50.XXXX.X250)	

CE-compliant according to EN 61 000-6-2, EN 61 000-6-4, EN 61 000-6-3

RoHS compliant acc. to EU guideline 2002/95/EG

function principle:

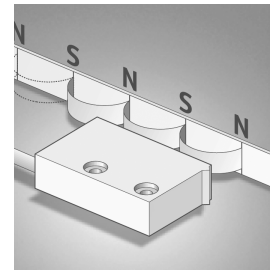

Signal figures

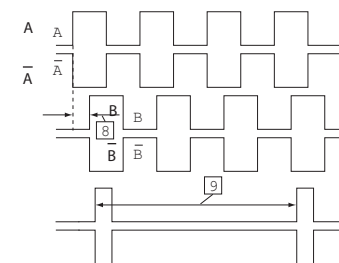

⁹⁾ periodic index signal (every 5 mm)

The logical assignment A, B and I-Signal can change

⁸⁾ Min. Pulse interval: pay attention to the instructions in the technical data

¹⁾ With supply voltage correctly applied

²⁾ A max. of one channel only may be short-circuited: (when +V = 5 V, a short circuit to another channel, 0 V, or +V is permissible.) (when +V = 5-30 V, a short circuit to another channel or to 0 V is permissible.)

³⁾ At the listed rotational speed the min. pulse interval is 1 μs, this corresponds to 250 kHz. For the max. rotational speed range a counter with a count input frequency of not less than 250 kHz should be provided.

Linear Magnetic Measurement System LI50/B2

Technical data magnetic band B2:

Pole gap:	5 mm from pole to pole
Dimensions:	Width: 10 mm, Thickness: 1.7 mm incl. masking tape
Temperature coefficient:	$(11 \pm 1) \times 10^{-6} / K$
Temperature ranges:	working temperature: -4 to +176°F (-20 to +80°C) storage temperature: -40 to +176°F (-40 to +80°C)
Mounting:	adhesive joint
Measuring:	0.1 m (to receive an optimal result of measurement, the magnetic band should be ca. 0.1 m longer than the desired measuring length)
Bending radius:	≥ 50 mm

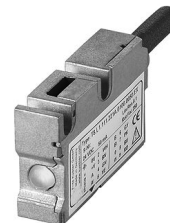

Pin configuration:

Pin	Signal	Color
1	0V	WH
2	+V	BN
3	A	GN
4	\bar{A}	YE
5	B	GY
6	\bar{B}	PK
7	Z	BU
8	\bar{Z}	RD

Shield is on the housing

Wiring Diagram:

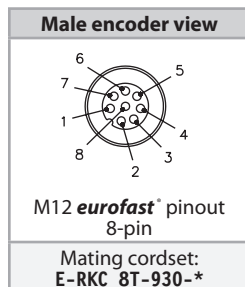

* Length in meters.

Part number key: Magnetic sensor LI50

T8.LI50.11X1.2XXX-XM-E-RSS 8T		Options for molded connection only.
Model		
Design	1 = standard	
Pulse interval	1 = standard	
Supply voltage and output circuit	1 = 4.8-26 VDC, RS422 2 = 4.8-30 VDC, push-pull	
Type of connection	1 = cable (PUR), 2 m	
		Connection (optional) E-RSS 8T = 8-pin M12 eurofast ®
		Mold on Length Overall length in meters. 0.2M = 0.2 meters
		Code (Resolution*) 050 = 25 μ m 250 = 5 μ m (only connected with magnetic band B2)
		Reference signal 2 = index periodic

* with quadruple evaluation

Part number key: Magnetic band B2

8.B2.10.010.XXXX	
Model	
Width	10 = 10 mm
	Length 0010 = 1 m 0050 = 5 m 0100 = 10 m Other lengths up to 50 m on request

Accessories:

- See page J1, Connectivity, for cables and connectors

Linear Magnetic Measurement System LI50/B2

Dimensions: Magnetic sensor LI50

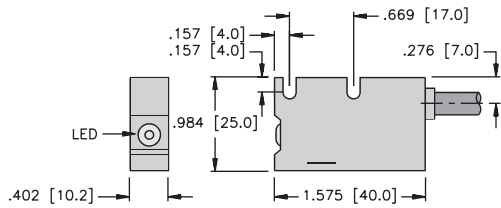

Dimensions: Magnetic band B2

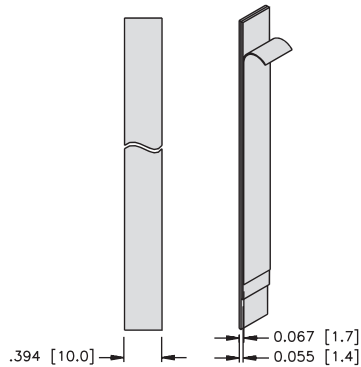

Permissible Mounting tolerances:

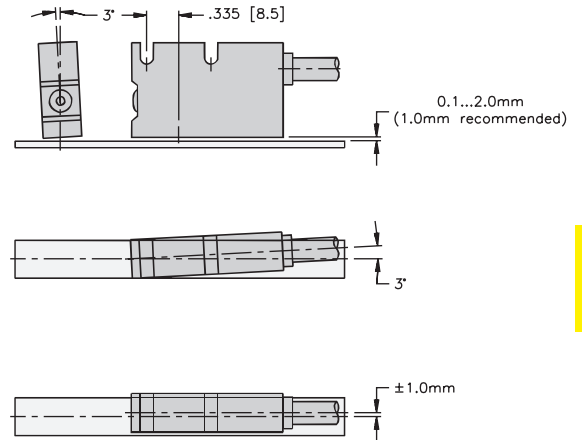

Display Type 572 for LIXX



Counter series with two individually scalable encoder inputs: HTL or TTL. In each case, A \bar{A} , B \bar{B} for count frequencies up to 1 MHz per channel. Operating modes may be selected for position or event counter, total counter, difference counter, cut-to-length display, diameter calculator, batch counter and more.

- Two, separate freely scalable count inputs – HTL or TTL – also with inverted inputs.
- Max. input frequency 1 MHz/ channel.
- Four freely programmable solid-state outputs, each with 350 mA output current.
- Step or tracking preset.
- AC and DC supply voltage.
- May be used as a counter or position display with limit values.
- Monitoring function, where two values are monitored or calculated with respect to each other.
- Four programmable inputs with various functions, such as reset, gate, display memory, reference input or switching between the display values.
- Optional scalable analog output 0/4 to 20 mA, +/-10 V or 0 to 10 V.
- Two auxiliary power supplies for sensors: 5.2 VDC and 24 VDC.
- Standard interface RS 232.

Part number key specification:

Position display, 6 digits, with 4 fast switch outputs and serial interface: 6.572.0116.D05

Position display, 6 digits, with 4 fast switch outputs and serial interface and scalable analog output: 6.572.0116.D95

Position display, 8 digits, with 4 fast switch outputs and serial interface: 6.572.0118.D05

Position display, 8 digits, with 4 fast switch outputs and serial interface and scalable analog output: 6.572.0118.D95

For detailed product specifications, see page G16.